

TUXCO

Model HCS - 30

Hydraulic Cylinder Servicer

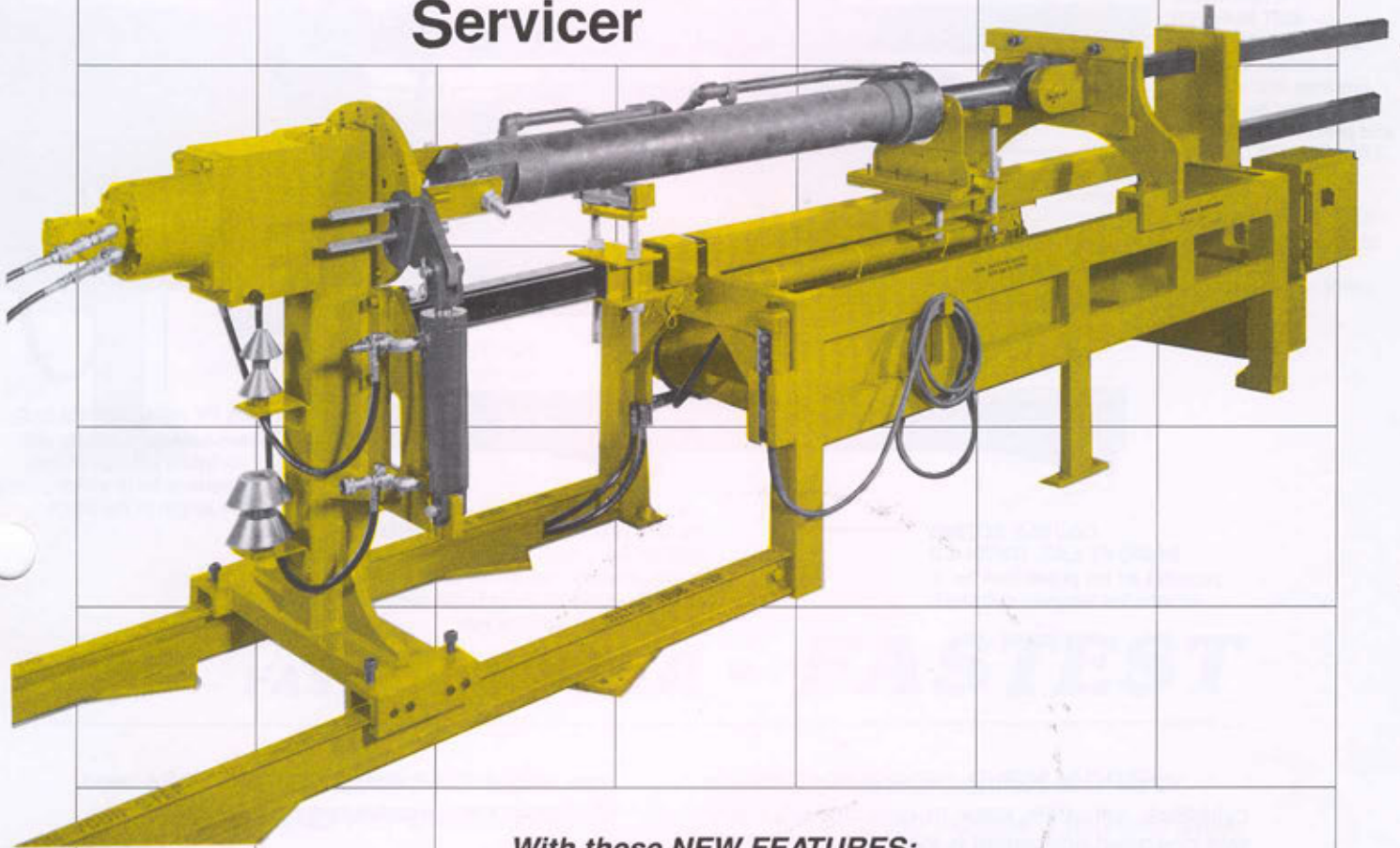

With these NEW FEATURES:

- 30,000 FT. LBS. OF AVAILABLE TORQUE
- HIGH SPEED HYDRAULIC NUT RUNNER
- CONVENIENT PENDANT FUNCTION CONTROL
- TIME SAVING CYLINDER MOUNTING SYSTEM

*plus all the features that have made
TUXCO the industry leader.*

TUXCO CORPORATION

4300 Grove Avenue, Gurnee, Illinois 60031-2155 USA

Tel.: 708-244-2220

FAX: 708-244-7335

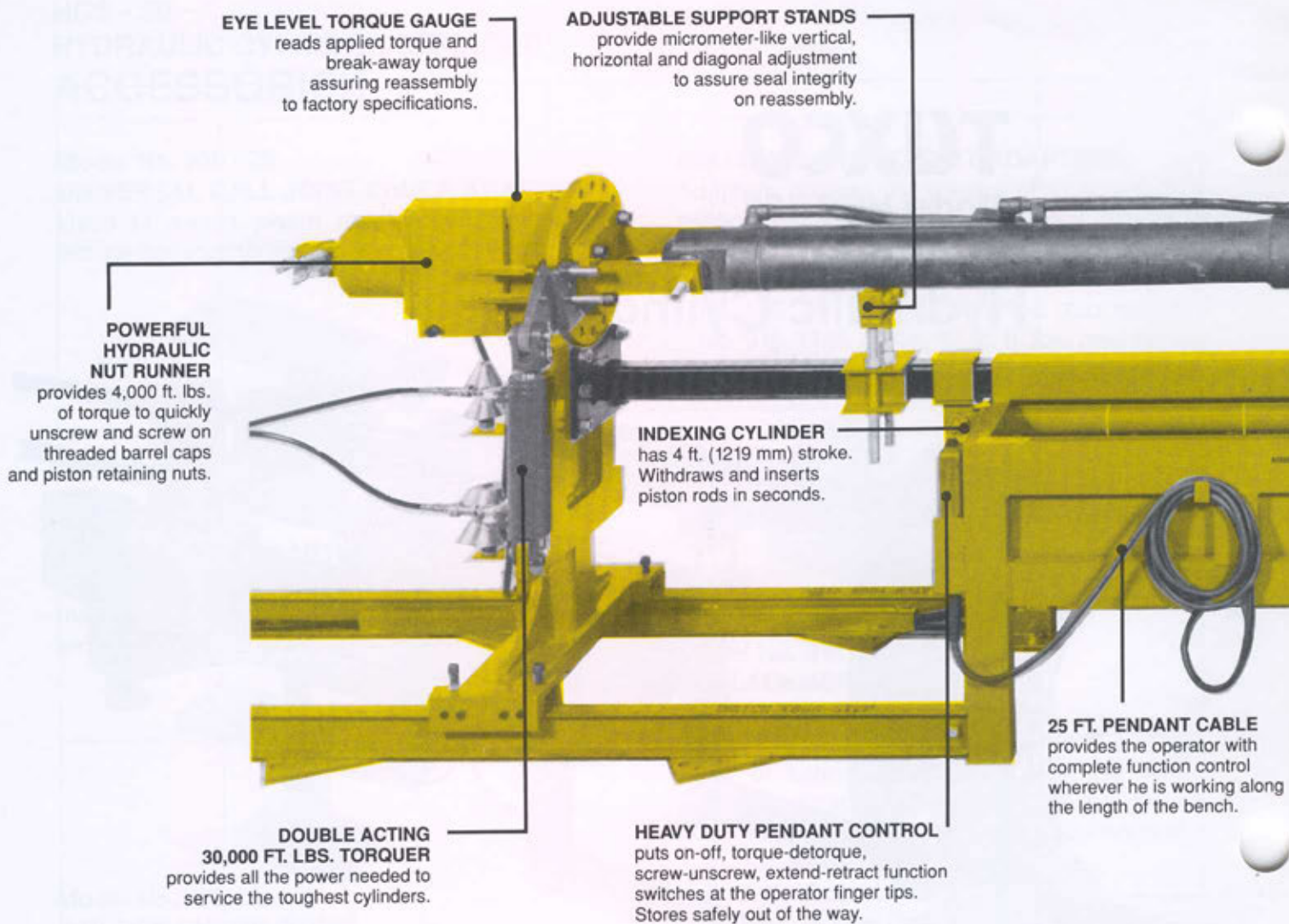

EYE LEVEL TORQUE GAUGE
reads applied torque and
break-away torque
assuring reassembly
to factory specifications.

ADJUSTABLE SUPPORT STANDS
provide micrometer-like vertical,
horizontal and diagonal adjustment
to assure seal integrity
on reassembly.

**POWERFUL
HYDRAULIC
NUT RUNNER**
provides 4,000 ft. lbs.
of torque to quickly
unscrew and screw on
threaded barrel caps
and piston retaining nuts.

INDEXING CYLINDER
has 4 ft. (1219 mm) stroke.
Withdraws and inserts
piston rods in seconds.

**DOUBLE ACTING
30,000 FT. LBS. TORQUER**
provides all the power needed to
service the toughest cylinders.

HEAVY DUTY PENDANT CONTROL
puts on-off, torque-detorque,
screw-unscrew, extend-retract
function switches at the operator
finger tips.
Stores safely out of the way.

25 FT. PENDANT CABLE
provides the operator with
complete function control
wherever he is working along
the length of the bench.

When your business is repairing hydraulic cylinders, versatile, easy to use, powerful and well designed equipment is the key to getting the job done fast and profitably. And that's what TUXCO's new HCS-30 Hydraulic Cylinder Servicer is all about – one man operation and greater efficiency and more profit.

Many of the HCS-30's features have been outlined above and what those features provide is this:

FAST SET UP

Just two sets of four conical mounting bushings handle cylinder eyes from 1.0" (25.4 mm) to 5.75" (146 mm) I.D. A third optional set handles 6.0" (152.4 mm) to 8.0" (203.2 mm) I.D.'s. No more searching through dozens of adapters. And the cone bushings are stored at

both ends of the machine where they are used. Metric bushings are not required.

TREMENDOUS TORQUE

Hydraulic torquing device provides up to 30,000 ft. lbs. (415 kg-m) of torque to loosen threaded barrel caps and piston retaining nuts. Because the torquer is double acting it never has to be moved. And that means the HCS-30 is not only a lot easier to use, but it can be installed very close to a wall, saving up to 150 sq. ft. (13.0 sq. m) of valuable floor space.

FAST POWERFUL ROD EXTRACTION

The HCS-30 hydraulically extracts an eight foot (2438.4 mm) piston rod in less than one minute. And there are tons of force available to handle heavy, tough rods. Rod insertion is even faster.

CONICAL MOUNTING BUSHINGS
fit a wide range of eye bushings
and provide speedy set ups
that add to profits.

EASILY ADJUSTABLE TAILSTOCK
speeds mounting of cylinders
from one to twenty feet
in extended length.

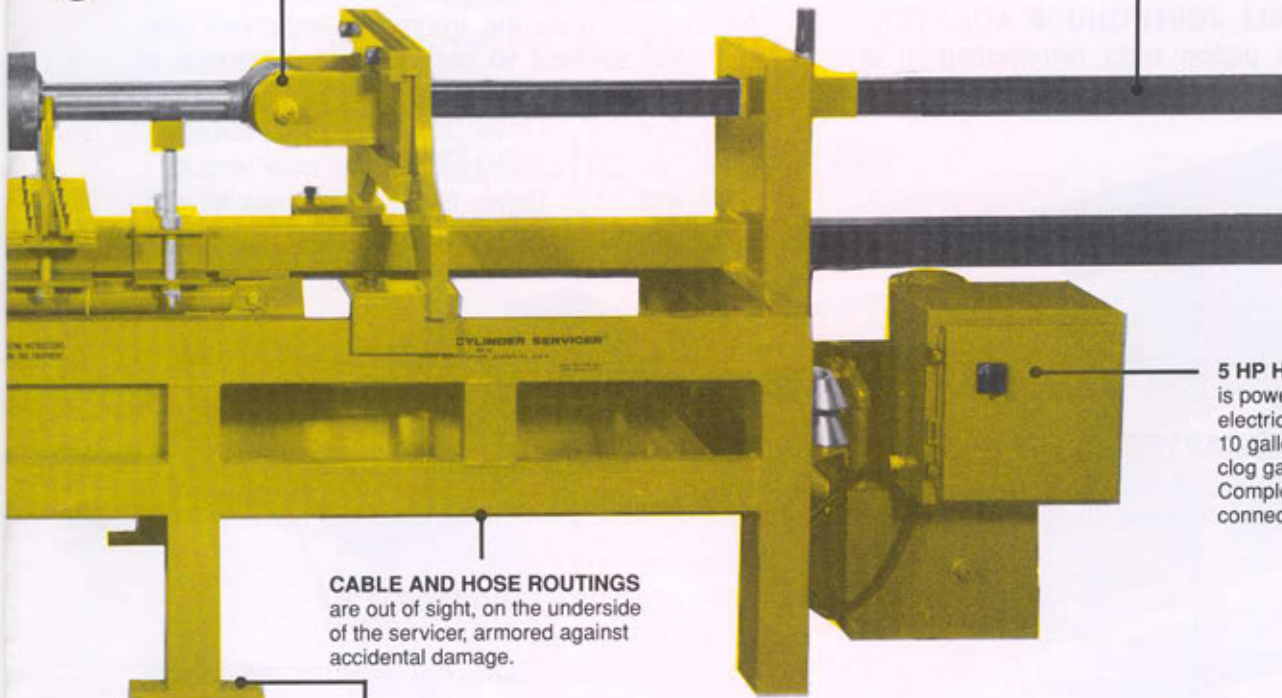

5 HP HYDRAULIC POWER UNIT
is powered by an all voltage
electric motor. The unit has a
10 gallon tank, sight gauge, filter,
clog gauge and solenoid controls.
Completely wired ready for
connection to your power system.

CABLE AND HOSE ROUTINGS
are out of sight, on the underside
of the servicer, armored against
accidental damage.

FLOOR MOUNTING HARDWARE
Installation is made easily by
detailed instructions. Floor
anchors and anchor tool
are included.

FAST - FASTER - FASTEST

HIGH SPEED CAP AND NUT REMOVAL AND REPLACEMENT

The HCS-30 has a hydraulic, geared head nut runner permanently mounted to the headstock chuck. At the push of a button, it provides up to 4000 ft. lbs. (553 kg-m) of torque at 6 r.p.m.

NEW CONTROLS PREVENT LOST MOTION

All functions are controlled by pendant mounted switches. On-off, extend-retract, torque-detorque and screw-unscrew functions are always at the operators finger tips. Special circuitry permits micro-jogging. When not in use pendant and cable have convenient storage places.

AND THERE'S EVEN MORE . . .

The HCS-30 includes a universal spanner. You won't need conventional spanner wrenches. It also includes a universal high torque wrench. You won't use expensive sockets. The unit is completely wired, you need only connect it to your electric service. We even include the floor anchors, anchoring tool and Allen wrenches that are required. You'll be up and running quickly.

Specifications subject to change without notice.

HCS - 30 HYDRAULIC CYLINDER SERVICER ACCESSORIES

Model No. 906 - 25

UNIVERSAL BALL JOINT CHUCK ADAPTER

Used to mount piston rods terminating in a female ball joint to the servicer T-slot chuck.



Model No. 908

BLANK CHUCK ADAPTER

Similar to 906 but with a blank face that can be machined to accept flanged lift truck cylinders, etc.



Model No. 909

V-BLOCK CHUCK WINGS

For mounting cylinders in Servicer chucks when the cylinder or rod does not have a pin bushing. For Headstock order No. 909. For Tailstock order No. 909 - 30.

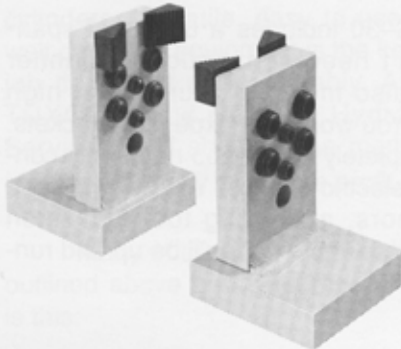

SQUARE DRIVE SOCKET ADAPTERS

Adapters provide the means of attaching conventional sockets to the headstock chucks of the HCS Series Servicers.

- No. 914 3/4" Drive, 300 ft. lbs. max torque
- No. 915 1" Drive, 750 ft. lbs. max torque
- No. 916 1 1/2" Drive, 2,000 ft. lbs. max torque
- No. 917 2 1/2" Drive, 10,000 ft. lbs. max torque

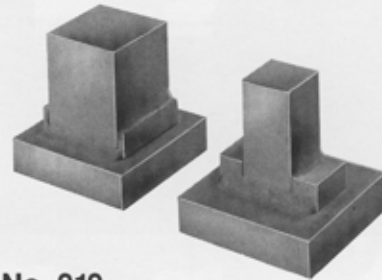

Model No. 919

REPLACEMENT SPANNER PIN ASSORTMENT

Each HCS Series Servicer includes this assortment of spanner pins used with the built-in Universal Spanner. The alloy pins are perishable. The replacement assortment consists of:

- 4 - 1/2" Square Pins (919 1/2 S)
- 4 - 1/2" Round Pins (919 1/2 R)
- 4 - 3/8" Round Pins (919 3/8 R)
- 4 - 1/4" Round Pins (919 1/4 R)

Model No. 965

UNIVERSAL WRENCH

Extra large Universal High Torque Wrench attaches to hex piston retaining nuts requiring 25,000 ft. lbs. of torque or less. Fits nuts from 4" to 6 1/2" across flats.

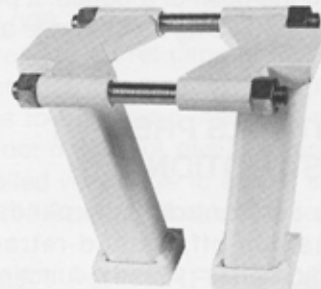

TUXCO CORPORATION

4300 Grove Avenue
Gurnee, Illinois 60031-2155
Telephone 708-244-2220
Fax 708-244-7335

